

1 2 3 4 5 6 7 8

REVISIONS		
ISS	ZONE	DESCRIPTION\PER REQUEST\DATE
B	B-3	NO.8 WAS CHANGED\RD-DW91082201W\08-22-02'

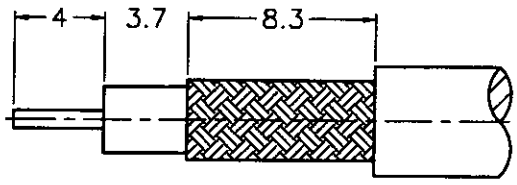

RECOMMENDED
CABLE STRIPPING DIM'S
(建議剝線尺寸)

SALES

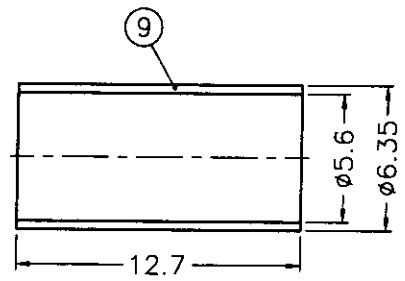
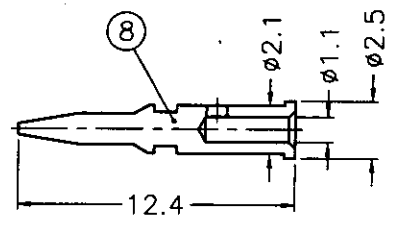
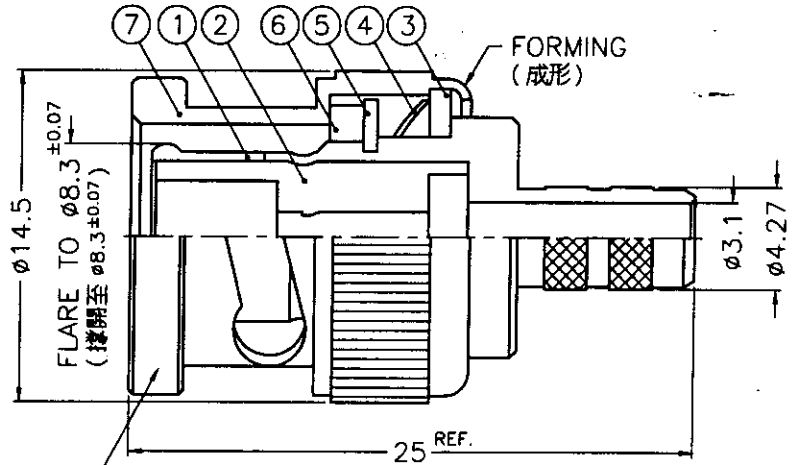

STAMP (IF ANY)
噴字 (若有要求)

- NOTES: FINISH (PLATING THICKNESS IN MICRO-INCHES)
- BRASS PER QQ-B-626
 - BRASS PER QQ-B-613
 - NICKEL PL. 100 MIN. THICK OVER COPPER STRIKE
 - NICKEL PL. 200 MIN. THICK OVER COPPER STRIKE
 - GOLD PL. 3 MIN. THICK OVER NICKEL PL. 100 MIN. THICK OVER COPPER STRIKE
 - JIS H 3250, C 2600

- CRIMPED FERRULE
HEX CRIMP SIZE .213"
- CRIMPED CONTACT PIN
HEX CRIMP SIZE .068"

ISSUED
2002. 8. 23
R&D

NO.	DESCRIPTION	MATERIAL	FINISH	Q'TY	DRAWING NO.
9	FERRULE			1	FR-635/56X127
8	CONTACT PIN			1	B50000-8-25/11
7	SHELL			1	B50000-1-B
6	GASKET	RUBBER	RED	1	GS-115/BX15
5	RETAINER RING			1	B50000-5
4	SPRING	SK5		1	B50000-6
3	WASHER			1	WS-128/9X08
2	INSULATOR	DELTRIN	NATURAL	1	B50000-3-50-A
1	BODY			1	B50000-2-427/31

DIMENSIONS ARE IN MILLIMETERS				PART NO.	
UNLESS OTHERWISE SPECIFIED TOLERANCES				APPROVED	DATE
0.5-6	= ±0.2	6-30	= ±0.4	<i>Mark C</i>	08-22-02'
30-120	= ±0.6	120-315	= ±1	<i>Karl J.</i>	08-22-02'
315-1000	= ±1.6	1000-2000	= ±2.4	<i>Angela W</i>	08-22-02'
SCALE	3/1	ISSUE	B	FILE NO.	F:\DWG\B\1121A1\223U-50\N03G

Amphenol - Kai Jack	
TAINAN TAIWAN	TITLE
BNC CRIMP PLUG (FOR RG-55/U, 142A/U, 400/U, 223/U)	DRAWING NO.
KJ-B1121A1-ND3G-223U-50	ITEM NO.
011121AAA26ND5F	

7RD-DR 15297 8

F

E

D

C

B

A

F

E

D

C

B

A